

## Vibrating tamper SRV 600i

**SRV 600i - anything but standard.**

Designed for a wide range of applications at a construction site, the SRV 600i offers everything you have come to expect from a powerful and robust tamper.

Its high level of operational safety can be attributed to many features, including, the air filtration system supplied by the engine manufacturer and the additional cyclone precleaner as well as the rugged engine protection.

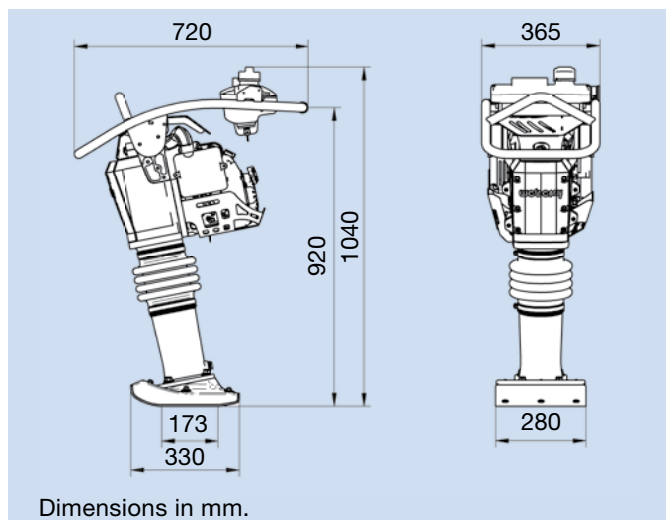

### Advantages of the SRV 600i

- ▶ Exceptional tamping performance.
- ▶ Proven, long-lasting tamping system offering a high level of wear resistance thanks to the use of high-quality materials.
- ▶ Fuel tank with integrated fuel filter; gas cap with ventilation and bleeding as well as a handy storage option while the tank is being filled.
- ▶ The low oil warning built into the Honda engine prevents the engine from starting if the oil level is too low.

## Technical data

Typ		SRV 600i
Operating weight CECE	kg (lbs)	63 (139)
Shoe width	mm (in.)	280 (11)
Percussion	per min.	700
Stroke	mm (in.)	65 (2,6)
Engine manufacturer		Honda GX 100
Engine type		4-stroke gasoline
Engine output max.	kW (HP)	2.1 (2.9)
Power output at operating speed	kW (HP) at r.p.m.	1.8 (2.5) at 4,100

We reserve the right to alter specifications.